

Independent Living 90° Care Slimline Hand Rails

FC8357L, FC8357R

- Designed to withstand 1100N (110 kg) force as per requirements
- Made from 304 stainless steel
- Concealed fixings (mounting screws included)

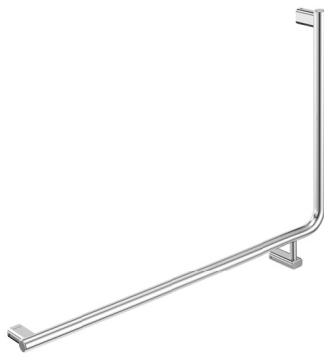

FC8357L

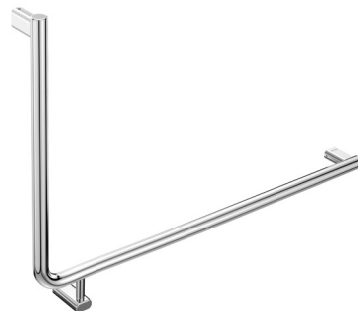

FC8357R

Installation Instructions

PLEASE READ CAREFULLY BEFORE INSTALLATION

NOTE: Hand Rails must be fitted to a solid wall or other firm surface and installed by a qualified tradesperson.

Grab rails are designed to withstand 1100N (110 kg) force as per requirements.

We suggest that grab rails are fastened at a minimum distance of 800mm from the floor with a clear space of 600mm above the rail.

WARNING: Over time, the mounting screws may become loose. You should periodically check that the Support Rail is fastened securely to the wall and re-tighten or replace the mounting screws when required.

Cleaning & Care

- Clean regularly using a mild liquid detergent and water.
- Do not use cream cleaners or bleach. These substances are abrasive.
- Do not use cleaning pads with abrasive surfaces as this may scratch the materials.

BEFORE INSTALLATION: CHECK ALL PARTS OF PRODUCT THOROUGHLY. INSTALLATION IS ACCEPTANCE OF GOODS AND WILL VOID WARRANTY. MIRRORS ARE FRAGILE. TAKE EXTRA CARE WHILE TRANSPORTING AND HANDLING GOODS.

Installation

Timber Support Wall: For fixing to a timber stud and non-structural walls, noggins or other suitable means of support must be used for the Support Rail. Using the correct drill bit to drill 8mm holes through the tile surface and then a 2mm pilot hole 60mm deep into the timber studs.

Structural Wall: brickwork, blockwork or concrete.

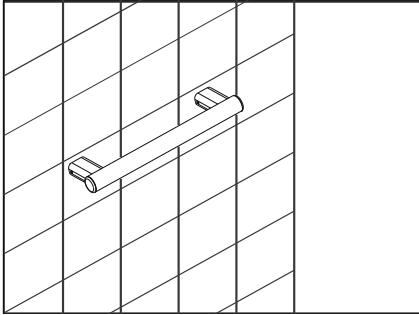

1. Determine the location on the wall where the support rail will be installed.

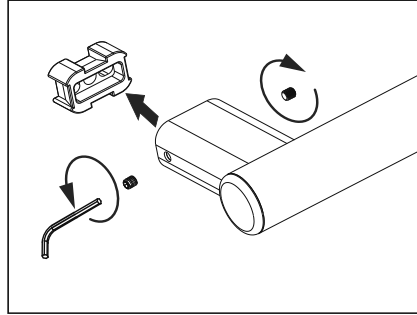

2. Remove the fixing bracket from inside the mounting arms by loosening the grub screws.

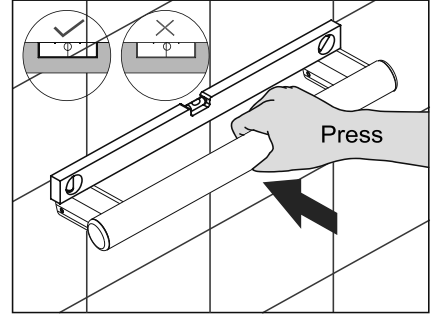

3. Place the hand rail against the wall with the mounting arms facing onto the wall. Using a level, make sure the mounting arms positions are straight and level.

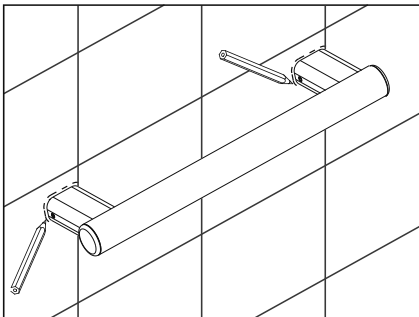

4. Using a pencil, trace around the mounting arms to mark the mounting spot. Remove the support rail from the wall.

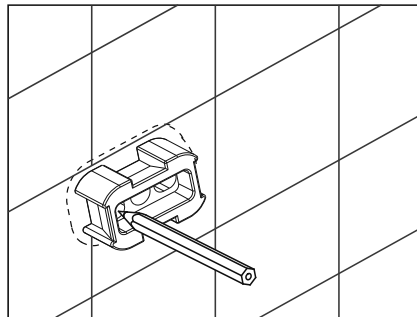

5. Place the fixing brackets in the centre position inside the traced area drawn on the wall and mark the drill holes.

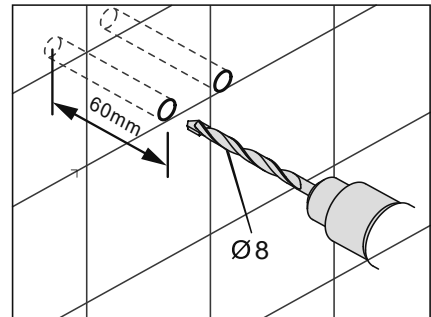

6. For fixing to brickwork, blockwork or concrete, using the correct drill bit, drill 8mm holes 60mm deep into the wall.

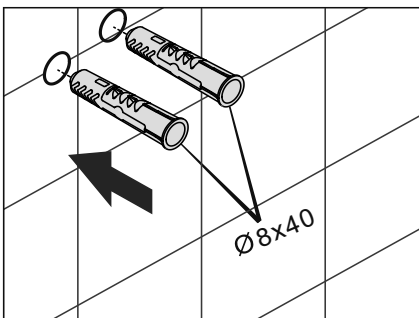

7. Insert suitable wall plugs into drilled holes. Ensure plugs are flush with wall.

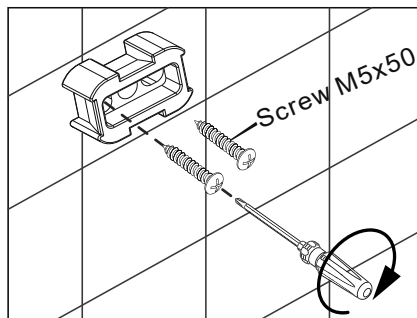

8. Using the 304 stainless steel screws provided, attach the mounting brackets securely to the wall.

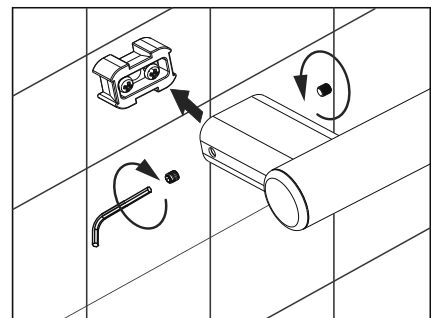

9. Slide the hand rail mounting arms over the fixing brackets on the wall and secure the rail by tightening all the grub screws.

THIS PAGE HAS BEEN INTENTIONALLY LEFT BLANK

Warranties

Residential Warranty Periods

Applies to domestic uses and applications of Fienza® products, such as private dwellings and retirement villages.

Commercial Warranty Periods

Applies to commercial uses and applications of Fienza® products, including, but not limited to: commercial food premises such as restaurants; commercial accommodation such as hotels; hospitals and healthcare facilities; public amenities; and industrial, laboratory and manufacturing facilities.



Full Warranty Terms

Product Component	Residential	Commercial
Structure Only	5 years replacement parts or product	5 years replacement parts or product
Finishes - PVD & Electroplated	5 years replacement parts or product	1 year replacement parts or product
Spare Parts	1 year replacement parts or product	1 year replacement parts or product

Australian Consumer Law

Our goods include guarantees that cannot be excluded under the Australian Consumer Law. You are entitled to a replacement or refund for a major failure and compensation for any other reasonably foreseeable loss or damage. You are also entitled to have the goods repaired or replaced if the goods fail to be of acceptable quality and the failure does not amount to a major failure.

Fienza Pty Ltd reserves the right to make changes in product characteristics, packaging or availability at any time without notice. Please visit fienza.com.au for the latest information.

Warranty Conditions

- Installation has been carried out by a licensed tradesperson in accordance with all applicable Building, Plumbing and Electrical codes, and Federal, State, or Local Government Regulations in accordance with AS/NZS 3500 Plumbing & Drainage, AS/NZS 6400 Water Efficient Products, and AS/NZS 3000 Electrical standards for any installations to which these standards apply.
- All maintenance and adjustments to the product after the installation have been carried out by a licensed tradesperson.
- All care and cleaning instructions have been adhered to as prescribed.
- All goods of substandard quality manufacture (excluding imperfections permitted within AS1976 - Vitreous China used in Sanitary Applications) will be credited or replaced by Fienza when advised within the warranty period, subject to prior inspection and agreement.
- Proof of purchase is required for warranty claims.

Warranty Limitations

To the extent permitted under the Trade Practices Act and other relevant legislation, Fienza's liability is limited to:

- The cost of replacing the goods, or
- The cost of obtaining equivalent goods, or
- The cost of having the goods repaired.
- Fienza is not responsible for any lack of operation or performance of goods (or any loss or damage) where goods are used or adapted for use with other goods not supplied by Fienza.
- It is the responsibility of the customer and installer before installation to ensure that all components are correct and free of obvious visible faults.
- Fienza is not responsible for the labour and rectification costs incurred in the above circumstance.

Conditions for On-Site Warranty Service Calls

Fienza will charge a service fee for each visit to an installation by its technician where it is determined that the fault is due to poorly executed or unlicensed installation work or where the product is not a genuine Fienza product or where the product is outside the warranty period. This may be paid in advance by credit card over the phone to a Fienza technician attending the site and will be refunded if the Fienza product is found to be at fault.

PLEASE LEAVE THIS MANUAL WITH THE END USER

For warranty support, please contact Fienza
 15 Walter Cres, Lawnton QLD 4501 | PO Box 5381, Brendale QLD 4500
P 07 3490 6700 **F** 07 3490 6719 **E** help@fienza.com.au **ABN** 76 136 411 311