

# Kaya®

## HEATED TOWEL RAIL

8286045



Concealed  
Wiring

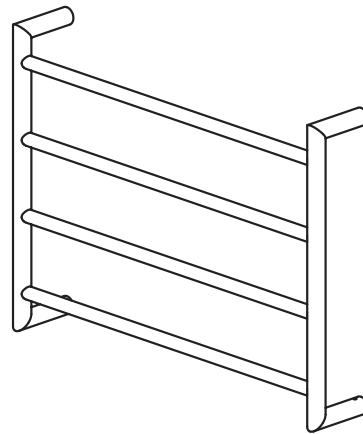

**PLEASE READ THROUGH THIS INSTALLATION GUIDE CAREFULLY BEFORE INSTALLING THE PRODUCT. Check the product thoroughly for damage. Installation is acceptance of goods supplied and will void warranty. Ensure all items meet your building or plumbing requirements before installation.**

### Specifications

Please refer to [fienza.com.au](http://fienza.com.au) for the latest product specifications before installing.

Overall Width	600 mm
Overall Height	450 mm
Overall Depth	100 mm
Voltage	230V
Power	45W (Matte Black is 47.5W)
IP Rating	IP55
Wiring Method	Concealed
Wiring Positions	Top right or bottom left

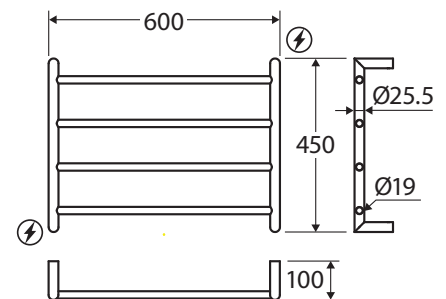

⚡ Wiring Positions

### Overview

All Fienza Heated Towel Rails are manufactured to the following standards and specifications:

- AS/NZ 3000
- Rated voltage – 230V
- IP Rating – IP55
- Touch temperature between 35°C and 60°C

The towel rail is designed for use in residential and hotel bathrooms and is intended for the purpose of drying towels and is therefore hot to touch. The towel rail **MUST** be installed as prescribed in accordance with local wiring rules and regulations, including the regulations covering installation of appliances and accessories in 'wet areas' such as bathrooms, showers and laundries. Installation should be in accordance with AS/NZS 3000.

## Safety Warnings & Information

As with any electrical appliance, you should be aware of basic safety precautions when using this heated towel rail. Please read these instructions and file for future reference.

The Heated Towel Rail in this installation guide is a dry element electric Heated Towel Rail. It should reach optimum operating temperature within 30 minutes of being switched on. Running temperature is approx. 35°C without a towel on the rail, 50-60°C with a towel on the rail. To dry the towel, it will take approx. 4 hours depending on ambient room temperature, the rail size, and the size and thickness of the towel.

1. This appliance **MUST** be installed by a licenced electrician, be protected by a suitably rated RCD circuit breaker and in accordance with the IP ratings for wet areas.
2. This appliance is not intended for use by persons (including children) with reduced physical, sensory, or mental capabilities, or lack of experience and knowledge, unless they have been given supervision or instruction concerning use of the appliance by a person responsible for their safety.
3. Children should be supervised to ensure that they do not play with the appliance.
4. For safety protection, this electrical appliance relies on the earth being connected to a residential device.
5. Use this appliance only on the voltage specified on the rating label.
6. The towel rail will get slightly hotter than normal during warmer weather and when insulated by towels.
7. **WARNING:** To avoid a hazard for very young children, this appliance should be installed so that the lowest heated rail is at least 600mm above the floor.
8. **DO NOT** immerse the towel rail in any liquid. It would be very dangerous to put the towels or anything else which has been in contact with hazardous liquids on this towel rail.
9. The power cord must be positioned so that it is not subject to splashing or ingress of moisture. The power cord should never touch heated surfaces. If the electrical cord or connection is damaged **DO NOT** attempt to repair, please contact the supplier.
10. To reduce the risk of injury, do not drape the power cord over the countertop or tabletop where it can be pulled down by children or tripped over.
11. A short power-supply cord (or detachable power-supply cord) has been provided to reduce risks of being entangled or tripping over.
12. Please ensure this device is installed, connected, and working correctly.

## Product Components

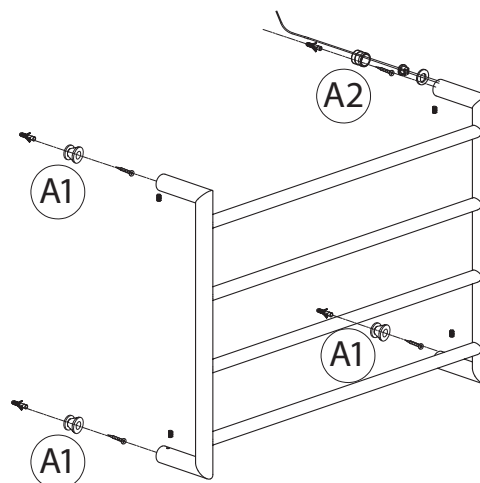
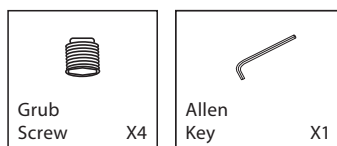
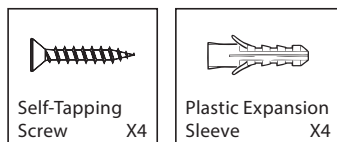
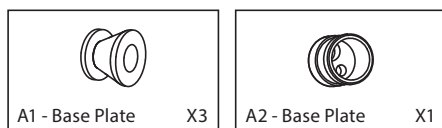
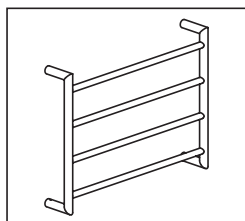

## Installation

There are two options for installing this Heated Towel Rail:

**CONCEALED WIRING (Hard-Wired)** – Provisions must be made for a switched supply wire to feed through the wall surface. The wire is located at the preferred mounting point for the towel rail. This type of installation MUST be performed by a licensed electrician.

**Wiring Method:** Top right or bottom left mounting points, hard-wired.

---

## Concealed Wiring Installation (Hard-Wired)

This appliance **MUST** be installed by a licensed electrician.

1. Remove the towel rail from the box. Check all parts are supplied against the Product Components list.
  2. Pull the electrical cord out from the leg that contains the electrical cord – top right or bottom left installation.
  3. Hold the towel rail up against the wall in the desired position. Using a pencil, draw a circle around each leg to mark the leg fixing positions on the wall. Remove the towel rail from the wall.
  4. Take the 4 base plates and hold them up against the wall inside the drawn circles. Make sure to use the A2 base plate at the desired electrical point and mark 2 holes, one for the screw hole and one for the electrical cord to pass through.
  5. Using a suitable drill bit, drill the holes to the required screw depth into the screw hole positions drawn on the wall at each fixing point.
  6. Push the plastic expansion sleeves into the drilled holes.
  7. Using the self-tapping screws, screw the A2 base plate onto the wall at the electrical wire connection point.
  8. Screw the 3 x A1 base plates onto the wall at the 3 non-electrical points.
  9. Once the 4 base plates are installed on the wall, hold the towel rail up onto the wall and cover the base plates with the legs of the towel rail. The electrical wiring cord must be connected to the power through the electrical outlet position, and insert through the A2 base plate at the electrical outlet position.
  10. Fasten the 4 legs to the base plates by using the 4 grub screws, place them in the small holes on each leg and fasten them to the base plate by using the Allen key provided.
- 

## Cleaning & Care

Fienza Heated Towel rails are manufactured from stainless steel (SUS304). It is recommended that you clean the heated towel rail with a soft damp cloth. Only use cleaning products suitable for stainless steel surfaces. Do not use acid based or abrasive cleaning products as this will damage the surface of the towel rail.

## Warranties

### Residential Warranty Periods

Applies to domestic uses and applications of Fienza® products, such as private residential dwellings and retirement villages.

### Commercial Warranty Periods

Applies to commercial uses and applications of Fienza® products, including, but not limited to: commercial food premises such as restaurants; commercial accommodation such as hotels; hospitals and healthcare facilities; public amenities; and industrial, laboratory and manufacturing facilities.

Product Component	Residential	Commercial
Structure Only	15 years replacement parts or product, 1 year labour	7 years replacement parts or product
Electrical	5 years replacement parts or product, 1 year labour	2 years replacement parts or product
Finishes - Chrome	15 years replacement parts or product, 1 year labour	7 years replacement parts or product
Finishes - PVD	10 years replacement parts or product, 1 year labour	5 years replacement parts or product, 1 year labour
Finishes - Powder Coated	2 years replacement parts or product, 1 year labour	1 year replacement parts or product

### Australian Consumer Law

Our goods come with guarantees that cannot be excluded under the Australian Consumer Law. You are entitled to a replacement or refund for a major failure and compensation for any other reasonably foreseeable loss or damage. You are also entitled to have the goods repaired or replaced if the goods fail to be of acceptable quality and the failure does not amount to a major failure.

Fienza Pty Ltd reserves the right to make changes in product characteristics, packaging or availability at any time without notice. Please visit [www.fienza.com.au](http://www.fienza.com.au) for the latest information.

### Warranty Conditions

- Installation has been carried out by a licensed tradesperson in accordance with all applicable Building, Plumbing and Electrical codes, and Federal, State, or Local Government Regulations in accordance with AS/NZS 3500 Plumbing & Drainage, AS/NZS 6400 Water Efficient Products, and AS/NZS 3000 Electrical standards for any installations to which these standards apply.
- All maintenance and adjustments to the product after the installation have been carried out by a licensed tradesperson.
- All care and cleaning instructions have been adhered to as prescribed.
- All goods of substandard quality manufacture (excluding imperfections permitted within AS1976 - Vitreous China used in Sanitary Applications) will be credited or replaced by Fienza when advised within the warranty period, subject to prior inspection and agreement.
- Proof of purchase is required for warranty claims.

### Warranty Limitations

To the extent permitted under the Trade Practices Act and other relevant legislation, Fienza's liability is limited to:

- The cost of replacing the goods, or
- The cost of obtaining equivalent goods, or
- The cost of having the goods repaired.
- Fienza is not responsible for any lack of operation or performance of goods (or any loss or damage) where goods are used or adapted for use with other goods not supplied by Fienza.
- It is the responsibility of the customer and installer before installation to ensure that all components are correct and free of obvious visible faults.
- Fienza is not responsible for the labour and rectification costs incurred in the above circumstance.

### Conditions for On-Site Warranty Service Calls

Fienza will charge a service fee for each visit to an installation by its technician where it is determined that the fault is due to poorly executed or unlicensed installation work or where the product is not a genuine Fienza product or where the product is outside the warranty period. This may be paid in advance by credit card over the phone to a Fienza technician attending the site and will be refunded if the Fienza product is found to be at fault.

For warranty support, please contact Fienza

15 Walter Cres, Lawnton QLD 4501 PO Box 5381, Brendale QLD 4500  
**P** 07 3490 6700 **F** 07 3490 6719 **E** [help@fienza.com.au](mailto:help@fienza.com.au) ABN 76 136 411 311

