

Stella

ADJUSTABLE LINK TOILET SUITE

K001



Soft Close

WELS 4 Star - 4.4L/3L (3.3L avg/flush)

- Boxed rim pan
- Gloss white finish
- Chrome flush buttons
- UF soft close seat with connector and flush pipe
- High quality, R&T flush mechanism
- Left or right bottom inlet
- Concealed S-Trap only, 140-255mm pan set-out

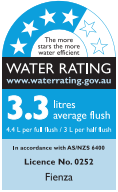

CHECK GOODS THOROUGHLY BEFORE INSTALLATION

Installation of received goods that are damaged, warped or faulty will void warranty. Ensure all items meet your plumbing requirements.



PLEASE LEAVE THIS GUIDE WITH THE OWNER

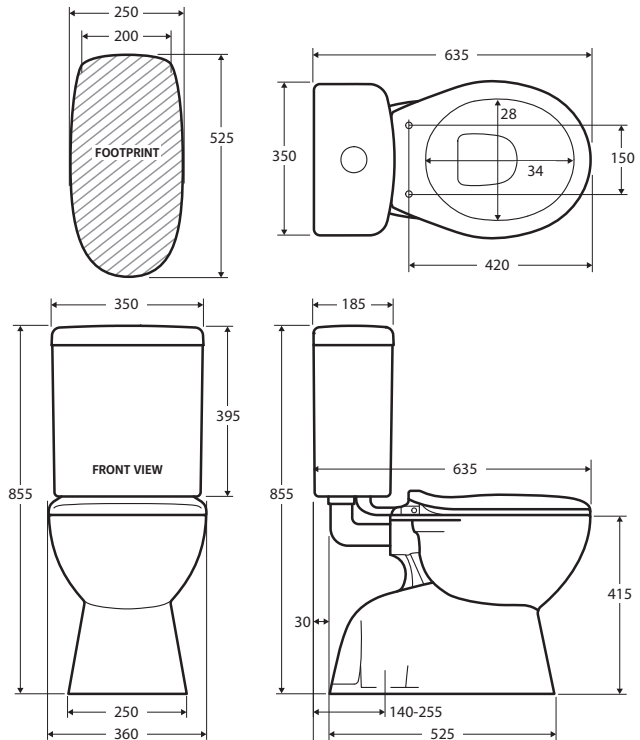

All installations should be carried out by a qualified tradesman in compliance with the National Plumbing & Drainage Code and any State or Local Authority Regulations, in accordance with AS/NZS 3500 series of standards and AS/NZA 6400. All measurements are in millimetres and are subject to change without notice. For ceramic products, please allow +/- 10 mm tolerance for manufacturing variance. Please refer to fienza.com.au for the latest product specification.

Parts List

| Description | Item Code |
|---|---------------|
| Pan | K001-P |
| Seat & Connector | K001-SEAT-NEW |
| Cistern | K001-C |
| Flush Buttons | 202073 |
| Pan Fixing Kit (Screws, Brackets, etc.) | 206344 |
| R&T Inlet Bottom Inlet | 200126 |
| R&T Outlet Bottom Inlet Taller | 200127 |
| Cistern Blank | 200125 |

! IMPORTANT

1. Make sure the water supply valve is shut off before installation.
2. Remove old bolts, silicon, putty, etc., from base area.

Parts

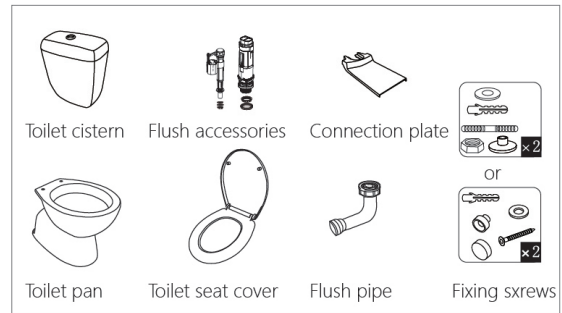

Tools (Not Included)



Installation

1. Seat installation

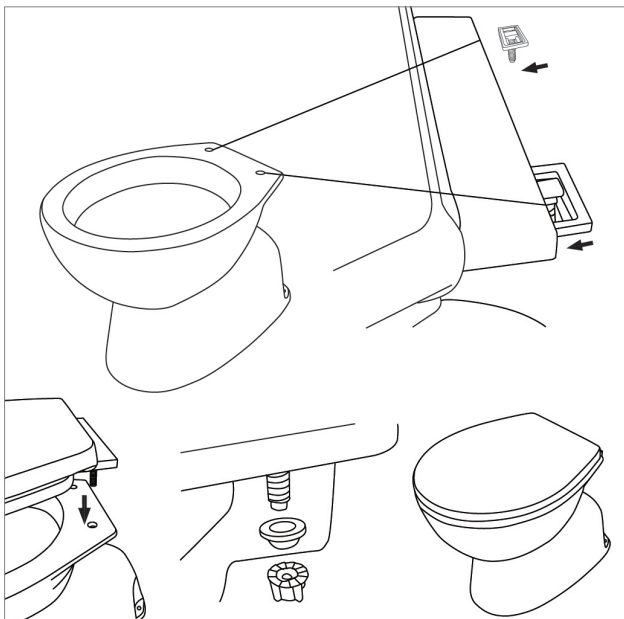

2. Flush accessories installation

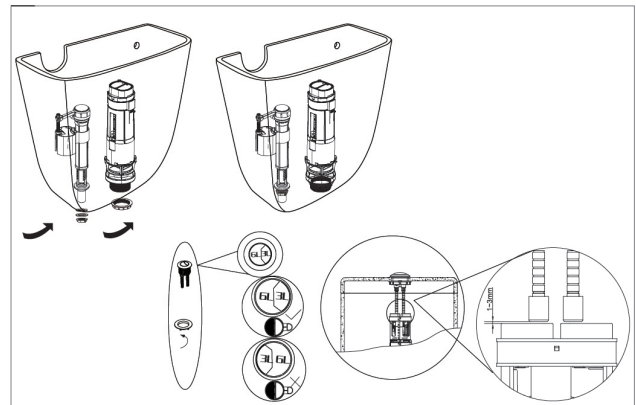

All installations should be carried out by a qualified tradesman in compliance with the National Plumbing & Drainage Code and any State or Local Authority Regulations, in accordance with AS/NZS 3500 series of standards and AS/NZA 6400. All measurements are in millimetres and are subject to change without notice. For ceramic products, please allow +/- 10 mm tolerance for manufacturing variance. Please refer to fienza.com.au for the latest product specification.

3. Wall-hung cistern installation

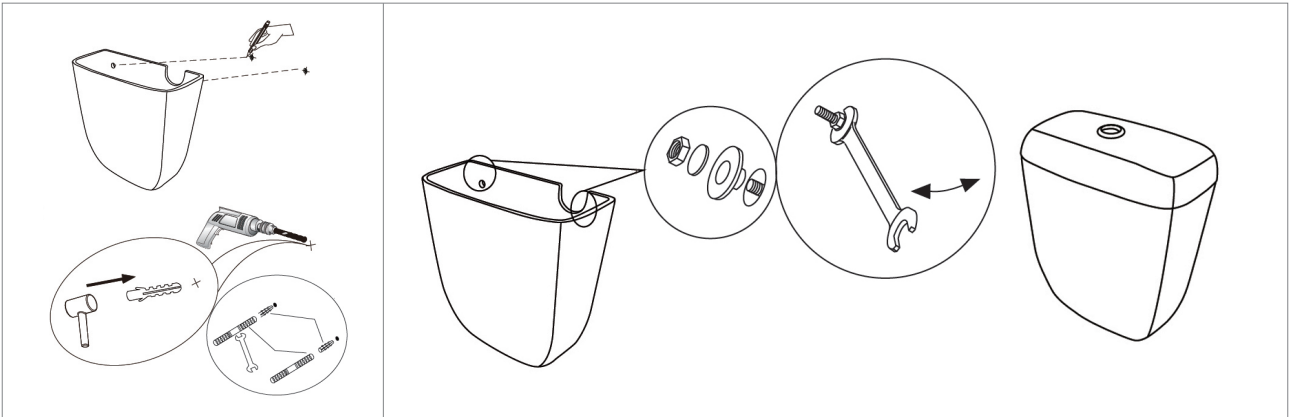

4. Connector and plate installation

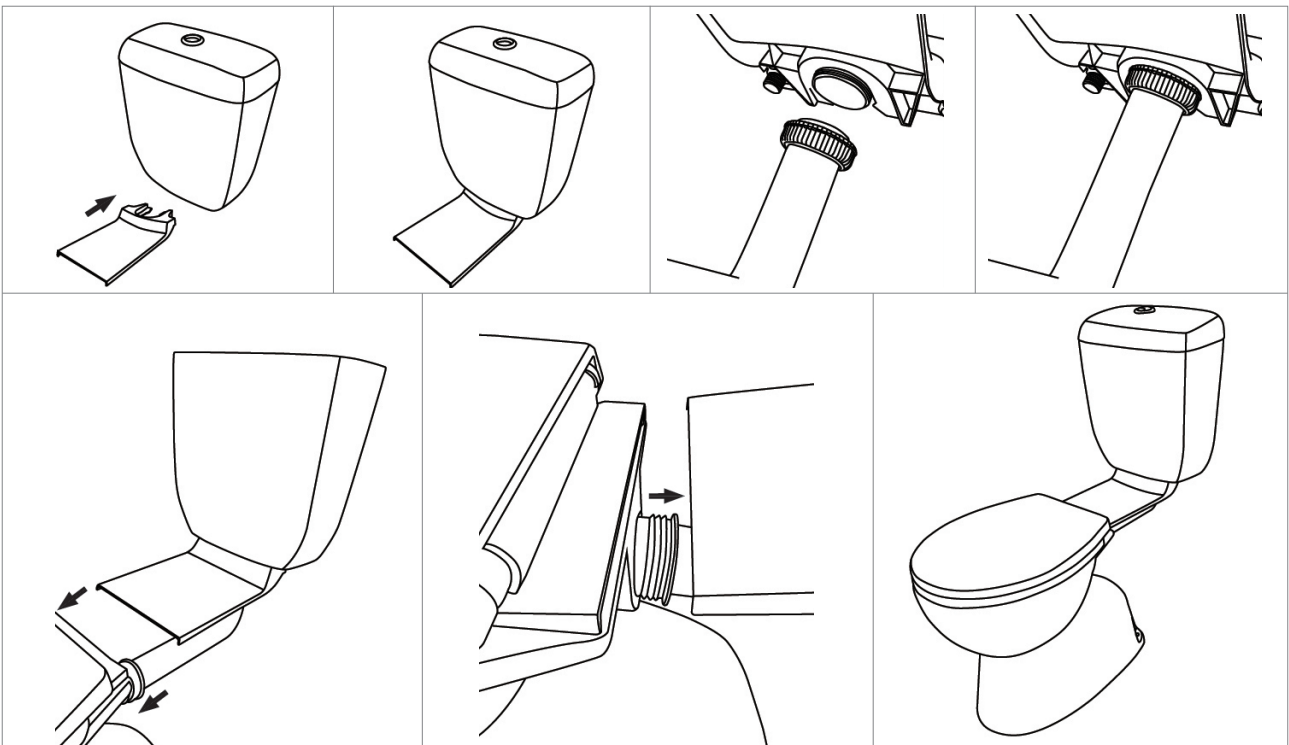

5. Screw mounting

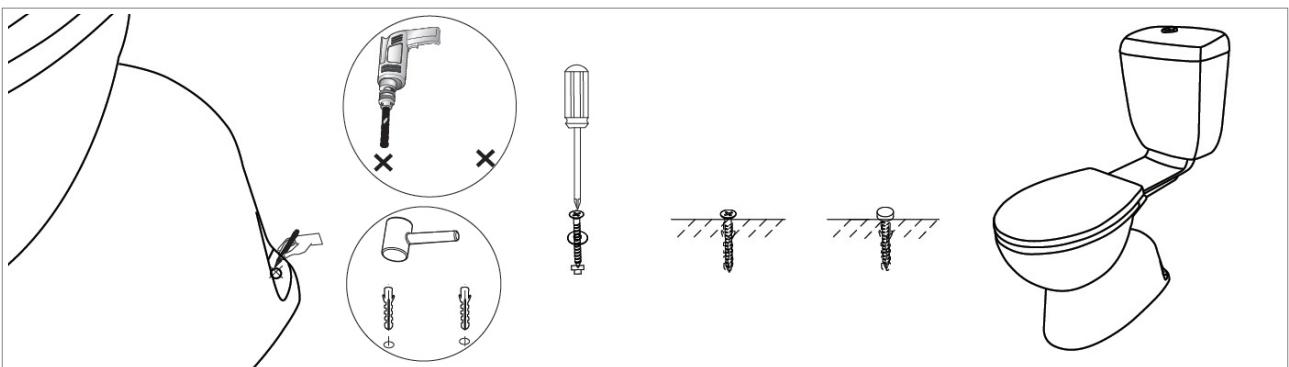

All installations should be carried out by a qualified tradesman in compliance with the National Plumbing & Drainage Code and any State or Local Authority Regulations, in accordance with AS/NZS 3500 series of standards and AS/NZS 6400. All measurements are in millimetres and are subject to change without notice. For ceramic products, please allow +/- 10 mm tolerance for manufacturing variance. Please refer to fienza.com.au for the latest product specification.

Warranties

Residential Warranty Periods

Applies to domestic uses and applications of Fienza® products, such as private dwellings and retirement villages.

Commercial Warranty Periods

Applies to commercial uses and applications of Fienza® products, including, but not limited to: commercial food premises such as restaurants; commercial accommodation such as hotels; hospitals and healthcare facilities; public amenities; and industrial, laboratory and manufacturing facilities.

| TOILETS* | | *Excludes parts subject to wear and tear such as rubber seals. |
|----------------------------------|---|--|
| Range / Component | Residential | Commercial |
| Vitreous China | 5 years replacement parts or product, 1 year labour | 3 years replacement parts or product, 1 year labour |
| R&T Cisterns (Tanks & Frames) | 5 years replacement parts or product, 1 year labour | 5 years replacement parts or product, 1 year labour |
| R&T Cisterns (Valves) | 3 years replacement parts or product, 1 year labour | 1 year replacement parts or product, 1 year labour |
| R&T Flush Button Plates | 2 years replacement parts or product | 1 year replacement parts or product |
| Seats, Accessories & Spare Parts | 1 year replacement parts or product | 1 year replacement parts or product |

Australian Consumer Law

Our goods come with guarantees that cannot be excluded under the Australian Consumer Law. You are entitled to a replacement or refund for a major failure and compensation for any other reasonably foreseeable loss or damage. You are also entitled to have the goods repaired or replaced if the goods fail to be of acceptable quality and the failure does not amount to a major failure.

Fienza Pty Ltd reserves the right to make changes in product characteristics, packaging or availability at any time without notice. Please visit www.fienza.com.au for the latest information.

Warranty Conditions

- Installation has been carried out by a licensed plumber in accordance with the plumbing code of Australia.
- All maintenance and adjustments to the product after the installation have been carried out by a licensed plumber.
- No additives have been introduced into the cistern tank.
- Only mild household detergents and soft (non-abrasive) cloth has been used to clean the product.
- All goods of substandard quality manufacture (excluding imperfections permitted within AS1976 - Vitreous China used in Sanitary Applications) will be credited or replaced by Fienza when advised within the warranty period, subject to prior inspection and agreement.
- Proof of purchase is required for warranty claims.

Warranty Limitations

To the extent permitted under the Trade Practices Act and other relevant legislation, Fienza’s liability is limited to:

- The cost of replacing the goods, or
- The cost of obtaining equivalent goods, or
- The cost of having the goods repaired.
- Fienza is not responsible for any lack of operation or performance of goods (or any loss or damage) where goods are used or adapted for use with other goods not supplied by Fienza.
- It is the responsibility of the customer and installer before installation to ensure that all components are correct and free of obvious visible faults.
- Fienza is not responsible for the labour and rectification costs incurred in the above circumstance.

Conditions for On-Site Warranty Service Calls

Fienza will charge a service fee for each visit to an installation by its technician where it is determined that the fault is due to poorly executed or unlicensed installation work or where the product is not a genuine Fienza product or where the product is outside the warranty period. This may be paid in advance by credit card over the phone to a Fienza technician attending the site and will be refunded if the Fienza product is found to be at fault.

For warranty support, please contact Fienza

15 Walter Cres, Lawnton QLD 4501 PO Box 5381, Brendale QLD 4500
 P 07 3490 6700 F 07 3490 6719 E help@fienza.com.au ABN 76 136 411 311

All installations should be carried out by a qualified tradesman in compliance with the National Plumbing & Drainage Code and any State or Local Authority Regulations, in accordance with AS/NZS 3500 series of standards and AS/NZA 6400. All measurements are in millimetres and are subject to change without notice. For ceramic products, please allow +/- 10 mm tolerance for manufacturing variance. Please refer to fienza.com.au for the latest product specification.