

Warranties

Residential: Applies to domestic uses and applications of Fienza® products, such as private dwellings and retirement villages.

Commercial: Applies to commercial uses and applications of Fienza® products, including, but not limited to: commercial food premises such as restaurants; commercial accommodation such as hotels; hospitals and healthcare facilities; public amenities; and industrial, laboratory and manufacturing facilities.

| Product Component | Residential | Commercial |
|---------------------------|--|--|
| Ceramic Disc Cartridges | LIFETIME replacement parts or product 15 years labour | 15 years replacement parts, 5 years labour |
| Mixer (Structure Only) | LIFETIME replacement parts or product, 1 year labour | 7 years replacement parts or product, 1 year labour |
| Finishes - Chrome | LIFETIME replacement parts or product, 1 year labour | 7 years replacement parts or product, 1 year labour |
| Finishes - PVD | 10 years replacement parts or product, 1 year labour | 1 year replacement parts or product, 1 year labour |
| Finishes - Electroplated | 5 years replacement parts or product, 1 year labour | 1 year replacement parts or product, 1 year labour |
| Accessories & Spare Parts | 1 year replacement parts or product | 1 year replacement parts or product |

NOTE: Excludes parts subject to general wear and tear such as O-rings, washers and jumper valves.

Australian Consumer Law

Our goods come with guarantees that cannot be excluded under the Australian Consumer Law. You are entitled to a replacement or refund for a major failure and compensation for any other reasonably foreseeable loss or damage. You are also entitled to have the goods repaired or replaced if the goods fail to be of acceptable quality and the failure does not amount to a major failure.

Warranty Conditions

- Installation has been carried out by a licensed tradesperson in accordance with AS/NZS 3500 and all applicable local regulations and plumbing codes.
- All care and cleaning instructions have been adhered to as prescribed.
- All maintenance and adjustments to the product after the installation have been carried out by a licensed tradesperson.
- Proof of purchase is required for warranty claims.

Warranty Limitations

To the extent permitted under the Trade Practices Act and other relevant legislation, Fienza's liability is limited to: the cost of replacing the goods; or, the cost of obtaining equivalent goods; or, the cost of having the goods repaired. Fienza is not responsible for any lack of operation or performance of goods (or any loss or damage) where goods are used or adapted for use with other goods not supplied by Fienza. It is the responsibility of the customer and installer before installation to ensure that all components are correct and free of obvious visible faults. Fienza is not responsible for the labour and rectification costs incurred in the above circumstance.

Conditions for On-Site Warranty Service Calls

Fienza will charge a service fee for each visit to an installation by its technician where it is determined that the fault is due to poorly executed or unlicensed installation work or where the product is not a genuine Fienza product or where the product is outside the warranty period. This may be paid in advance by credit card over the phone to a Fienza technician attending the site and will be refunded if the Fienza product is found to be at fault.

PLEASE LEAVE THIS GUIDE WITH THE OWNER

For more information, contact us or visit our website:

P: (07) 3490 6700 **E:** help@fienza.com.au **W:** fienza.com.au

Updated: 17/10/2024

fienza®

INSTALLATION GUIDE

Kaya

POT FILLER

228120-LF

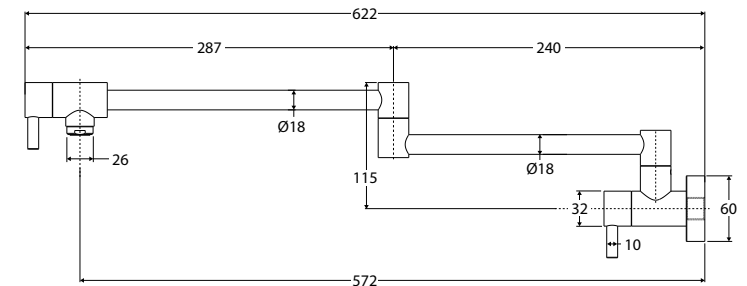
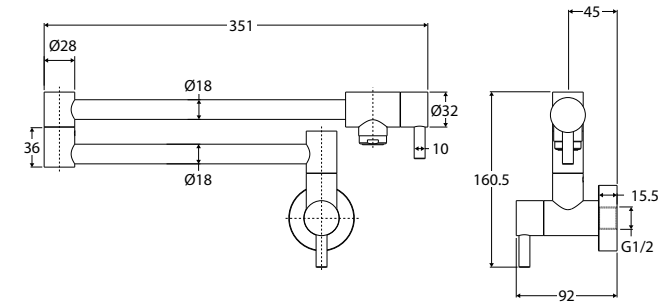

IMPORTANT: Please read all of the instructions before installation. Check goods thoroughly before installation. Installation of received goods that are damaged, warped or faulty will void warranty. Ensure all items meet your plumbing requirements. This product is pre-assembled. Do not disassemble, as this may void the warranty.

Watermark Scope of Use

- This product must be installed by a qualified licensed plumber in accordance with the National Construction Code Volume Three, AS/NZS 3500 and all applicable local regulations and plumbing codes.
- The product is intended for residential and commercial indoor use only.
- This product meets the lead free requirements of AS/NZS 4020 and Watermark licensing requirements.
- All pipe work must be thoroughly flushed prior to installation.
- Do not remove the ceramic cartridge from the mixer when installing.
- After installation all hoses and connections must be checked for leaks.
- It is the responsibility of the installer to ensure a waterproof seal is achieved between the product and mounting surface.
- The flow controller incorporated in the outlet must be re-tightened to prevent removal by hand.
- See below specifications for minimum and maximum operating pressures and temperature and other installation requirements.

Specifications

Please refer to fienza.com.au for the latest product specifications before installing.

| | |
|-----------------------|--|
| Mixer Type | 25 mm cartridge |
| Operating Pressure | Min: 150 kPa / 1.5 bar Max: 500 kPa / 5 bar Optimum: 350 kPa / 3.5 bar |
| Operating Temperature | 5°C - 39°C |
| Inlet Connections | 1/2" BSPP |
| WELS Rating | 5 Star rated, 6L/min |

Installation

IMPORTANT: Before commencing installation, turn off the water supply. While not essential, we recommend fitting isolation valves to both the hot and cold-water supply.

1. Use the mixer as an aid to locate the positioning of the fixing bracket. We recommend installing the centre point of the inlet approximately 300-350mm above your kitchen stovetop.

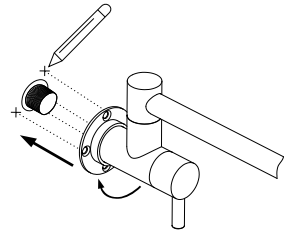

2. Mark the holes. Fix the bracket.

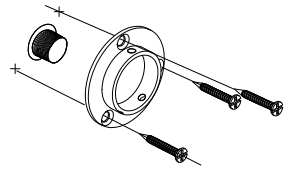

3. Push the cover plate over the body of the tap.

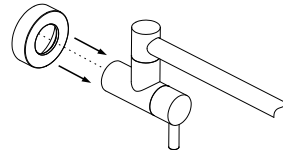

4. Screw the mixer onto the 1/2 inch threaded pipe (use appropriate thread sealant). Ensure the mixer is tight and in upright position.

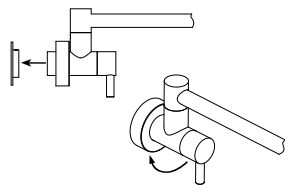

5. Tighten the grub screw with the allen key.

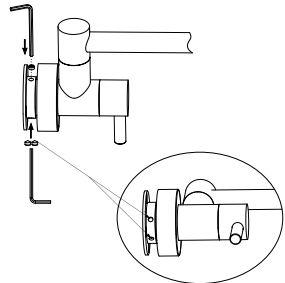

6. Finally push the cover plate over the fixing bracket. Test and commission before use. Any flow controller incorporated in the outlet is to be tightened to prevent removal by hand.

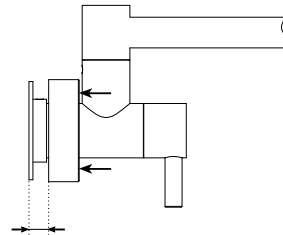

Cleaning & Care

We recommend weekly cleaning with mild soapy water and a microfiber cloth. In highly polluted or coastal locations we recommend cleaning 2-3 times per week. Please note that colour tapware requires more frequent cleaning than chrome tapware.

- Never use harsh detergents, citrus-based cleaners or abrasive cleaners, as these will scratch the surface. Use of unsuitable cleaners may damage the surface and will not be covered by warranty.
- Where your tapware remains dry in use, a non-abrasive soft cloth can be used to remove surface dust.
- Use of wax-based furniture cream should be avoided as these can result in a build-up of deposits which could detract from the appearance.
- Do not use undue pressure and wipe in one direction only.