

Warranties

Residential: Applies to domestic uses and applications of Fienza® products, such as private dwellings and retirement villages.

Commercial: Applies to commercial uses and applications of Fienza® products, including, but not limited to: commercial food premises such as restaurants; commercial accommodation such as hotels; hospitals and healthcare facilities; public amenities; and industrial, laboratory and manufacturing facilities.

Product Component	Residential	Commercial
Ceramic Disc Cartridges	15 years replacement parts, 15 years labour	15 years replacement parts, 5 years labour
Mixer (Structure Only)	15 years replacement parts or product, 1 year labour	7 years replacement parts or product, 1 year labour
Finishes - Chrome	15 years replacement parts or product, 1 year labour	7 years replacement parts or product, 1 year labour
Finishes - PVD	10 years replacement parts or product, 1 year labour	1 year replacement parts or product, 1 year labour
Finishes - Electroplated	5 years replacement parts or product, 1 year labour	1 year replacement parts or product, 1 year labour
Accessories & Spare Parts	1 year replacement parts or product	1 year replacement parts or product

NOTE: Excludes parts subject to general wear and tear such as O-rings, washers and jumper valves.

Australian Consumer Law

Our products come with guarantees that cannot be excluded under the Australian Consumer Law. You are entitled to a replacement or refund for a major failure upon inspection by an authorised representative where a product is found to be defective in construction, material or assembly. You are also entitled to have the goods repaired or replaced if the goods fail to be of acceptable quality and the failure does not amount to a major failure, free of charge.

Warranty Conditions

- Installation has been carried out by a licensed tradesperson in accordance with AS/NZS 3500 and all applicable local regulations and plumbing codes.
- All care and cleaning instructions have been adhered to as prescribed.
- All maintenance and adjustments to the product after the installation have been carried out by a licensed tradesperson.
- Proof of purchase is required for warranty claims.

Warranty Limitations

To the extent permitted under the Trade Practices Act and other relevant legislation, Fienza's liability is limited to: the cost of replacing the goods; or, the cost of obtaining equivalent goods; or, the cost of having the goods repaired. Fienza is not responsible for any lack of operation or performance of goods (or any loss or damage) where goods are used or adapted for use with other goods not supplied by Fienza. It is the responsibility of the customer and installer before installation to ensure that all components are correct and free of obvious visible faults. Fienza is not responsible for the labour and rectification costs incurred in the above circumstance.

Conditions for On-Site Warranty Service Calls

Fienza will charge a service fee for each visit to an installation by its technician where it is determined that the fault is due to poorly executed or unlicensed installation work or where the product is not a genuine Fienza product or where the product is outside the warranty period. This may be paid in advance by credit card over the phone to a Fienza technician attending the site and will be refunded if the Fienza product is found to be at fault.

PLEASE LEAVE THIS MANUAL WITH THE END USER

For more information, contact us or visit our website:

P: (07) 3490 6700 **E:** help@fienza.com.au **W:** fienza.com.au

Updated: 16/03/2023

fienza®

INSTALLATION GUIDE

Sansa

WALL MIXER, ROUND PLATE

229101

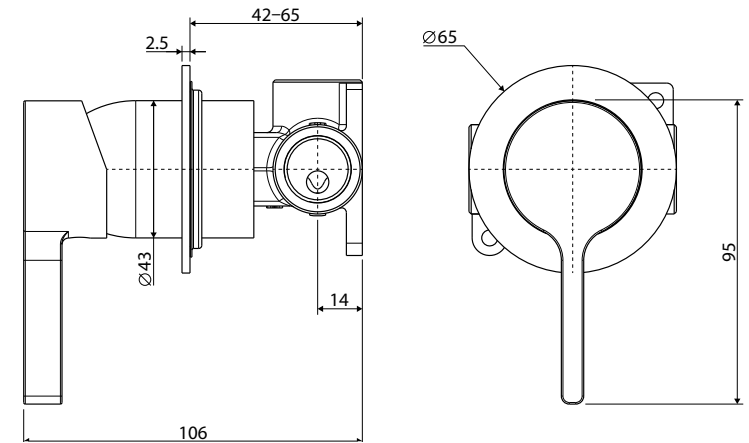

IMPORTANT: Please read all of the instructions and check goods thoroughly before installation. Installation of received goods that are damaged, warped or faulty will void warranty. Ensure all items meet your plumbing requirements. This product is pre-assembled. Do not disassemble, as this may void the warranty.

Specifications

Please refer to [fienza.com.au](https://www.fienza.com.au) for the latest product specifications before installing.

Mixer Type	35 mm cartridge
Operating Pressure	Min: 150 kPa / 1.5 bar Max: 500 kPa / 5 bar Optimum: 350 kPa / 3.5 bar
Operating Temperature	Hot: Max 80°C Cold: Min. 5°C
Inlet Connections	1/2" BSPP
Suitable Hot Water Units	Storage tank and continuous flow only. Not suitable for gravity feed.

General Information

- This product must be installed by a qualified licensed plumber in accordance with AS/NZS 3500 and all applicable local regulations and plumbing codes.
- All pipe work must be thoroughly flushed prior to installation.
- Do not remove the ceramic cartridge from the mixer when installing.
- After installation all hoses and connections must be checked for leaks.
- It is the responsibility of the installer to ensure a waterproof seal is achieved between the product and mounting surface.

Installation

IMPORTANT: Before commencing installation, turn off the water supply. While not essential, we recommend fitting isolation valves to both the hot and cold-water supply.

1. Remove product from packaging and check for damages. If the product is damaged in any way, do not install and return to the store where the item was purchased.
2. Fasten screws (13) to secure the mixer assembly in place.
3. Attach water supply to the hot and cold water inlets as marked on the body (10).
4. When all other plumbing has been fitted, turn on the water supply and check carefully for leaks. Re-tighten fittings if necessary.
5. During wall construction ensure that the mounting threads are exposed to allow fitting of the sleeves, cover plate, and handle.
6. Once the wall has been finished, remove the protective cover (12) by removing the screw (11).
7. Push the cover sleeve (6) over the body and screw into place by hand.
8. Push the cover plate (4 and 5) over the cover sleeve (6) until it is flush with the wall.
9. Fit the handle (3) onto the cartridge (9).
10. Use the allen key (14) and screw the grub screw (1) into the back of the handle to secure. Fit the hole cap (2).

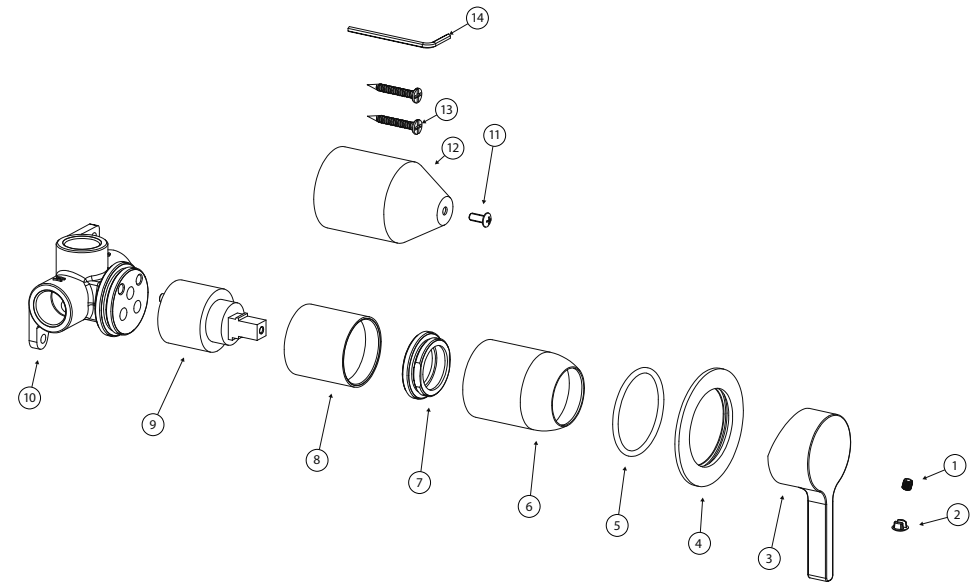

Cleaning & Care

We recommend weekly cleaning with mild soapy water and a microfibre cloth. In highly polluted or coastal locations we recommend cleaning 2-3 times per week. Please note that colour tapware requires more frequent cleaning than chrome tapware.

- Never use harsh detergents, citrus-based cleaners or abrasive cleaners, as these will scratch the surface. Use of unsuitable cleaners may damage the surface and will not be covered by warranty.
- Where your tapware remains dry in use, a non-abrasive soft cloth can be used to remove surface dust.
- Use of wax-based furniture cream should be avoided as these can result in a build-up of deposits which could detract from the appearance.
- Do not use undue pressure and wipe in one direction only.

1	Screw
2	Hole Cap
3	Handle
4	Plate
5	O-ring
6	Cover Sleeve
7	Lock Nut
8	Cartridge Sleeve
9	Cartridge
10	Body
11	Screw
12	Protective Cover
13	Screw
14	Allen Key